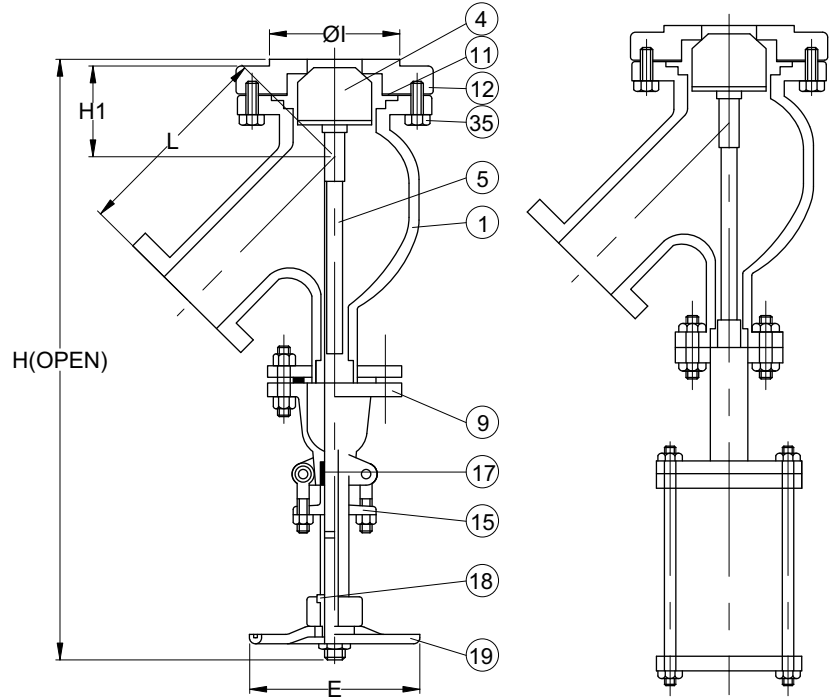

Fig No: YTV 2"x1/2"~ 12"x10"



MATERIALS LIST

NO.	PART NAME	MATERIALS
1	BODY	304/316
4	DISC	304
5	STEM	304/316
9	BONNET	304/316
11	GASKET	TEFLON
12	SEAT FLANGE	A182-F30/A182-F316
15	GLAND	304
17	GLAND PANKING	V#7233
18	YOKE SLEEVE	BRONZE
19	HAND WHEEL	FC
35	BOLT/NUT	SUS304

TEST PRESSURE TO API 598

	ANSI 150LB
BODY TEST(WATER)	25kg/cm2
SEAT TEST(WATER)	16kg/cm2

45° DIMENSION TABLE:

unit:mm

SIZE	d	L	E	H1	H	ØI
2"x1 1/2"	1-1/2"	165.0	180.0	60.0	450.0	60.0
2 1/2"x2"	2"	175.0	180.0	60.0	450.0	65.0
3"x2"	2"	200.0	220.0	80.0	470.0	81.0
4"x2"	2"	200.0	250.0	80.0	480.0	107.0
4"x3"	3"	240.0	250.0	100.0	490.0	107.0
5"x3"	3"	250.0	290.0	110.0	620.0	122.0
5"x4"	4"	260.0	290.0	110.0	620.0	122.0
6"x4"	4"	260.0	290.0	130.0	640.0	154.0
6"x5"	5"	270.0	290.0	130.0	640.0	172.0
8"x5"	5"	280.0	400.0	140.0	690.0	210.0
8"x6"	6"	300.0	400.0	150.0	920.0	210.0
10"x8	8"	340.0	500.0	165.0	1000.0	225.0
12"x10	10"	370.0	500.0	180.0	1100.0	225.0

60° DIMENSION TABLE:

unit:mm

SIZE	d	L	E	H	H1	ØI
2"x1 1/2"	1-1/2"	150.0	180.0	400.0	110.0	60.0
2 1/2"x2"	2"	150.0	180.0	440.0	110.0	68.0
3"x2	2"	160.0	220.0	450.0	110.0	81.0
4"x2	2"	170.0	250.0	470.0	115.0	96.0
4"x3	3"	180.0	250.0	500.0	115.0	96.0
5"x3	3"	190.0	290.0	550.0	120.0	122.0
5"x4	4"	200.0	290.0	550.0	120.0	122.0
6"x4	4"	220.0	290.0	600.0	125.0	154.0
6"x5	5"	220.0	290.0	600.0	125.0	172.0
8"x5	5"	230.0	400.0	680.0	135.0	210.0
8"x6	6"	230.0	400.0	700.0	145.0	210.0
10"x8	8"	260.0	500.0	890.0	150.0	225.0
12"x10	10"	290.0	500.0	950.0	165.0	225.0