

Fig No: YF-150

1/2" - 14" DN15-350



Features :

Sand Castings Component
 Bolted cover for DN50 & above,
 Screwed cover for smaller sizes
 Covers furnished with blow-off plug.
 For general industrial and chemical application
 Carbon steel available upon available

Standard Compliance :

Body wall thickness : B 16.34
 Face to Face : ANSI B 16.10 Class 150
 Flange dimension : ANSI B16.5 Class 150
 Body Material : ASTM A351
 Pressure testing : EN 12266

Specification :

End connection : Flange RF
 Working pressure : 275 psi (CWP)
 Temperature : -20 ~ 180°C

Options :

Double Screen (40 ~200 mesh)

MATERIALS LIST

NO.	PART NAME	MATERIAL
1	BODY	ASTM A351 Gr.CF8M
2	PLUG	ASTM A351 Gr.CF8M
4	SCREEN	SS304
9	CAP	ASTM A351 Gr.CF8M
11	BODY SEAL	PTFE.
35	BOLT	ASTM A193 Gr.B8

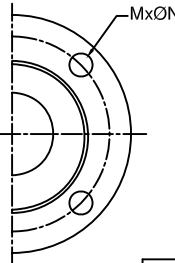
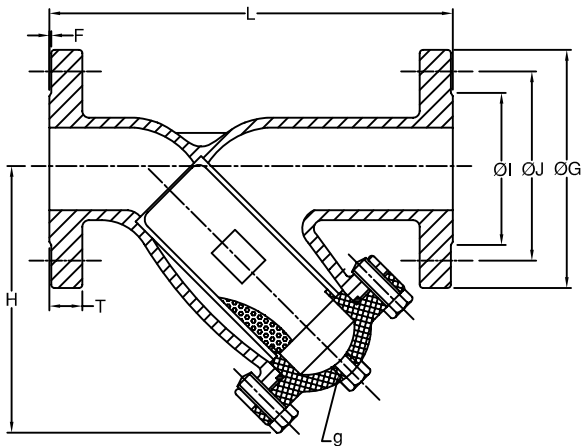
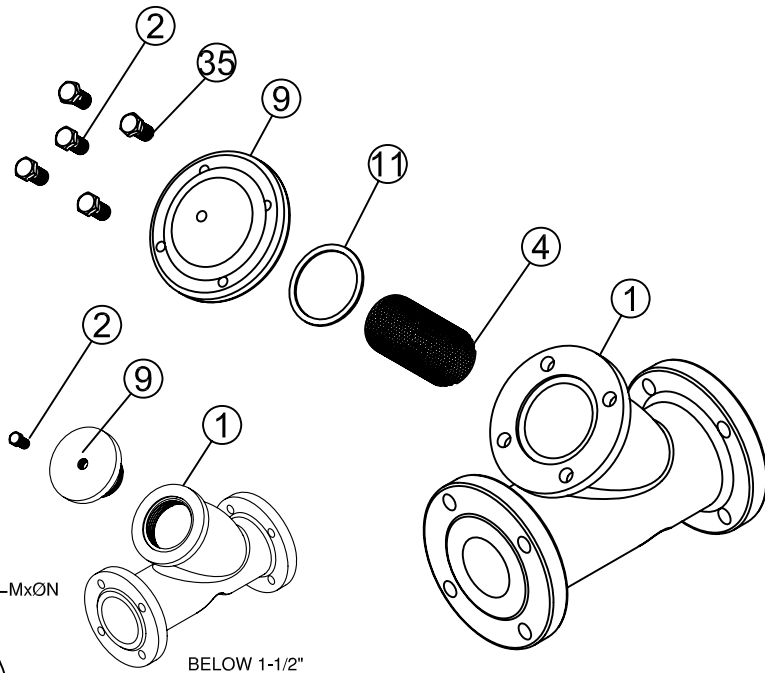

BELOW 1-1/2"



BELOW 1-1/2"

DIMENSIONS

SIZE	L	H	ØG	ØJ	ØI	T	F	M	ØN	unit:mm
DN15	1/2"	152.0	70.0	89.0	60.5	35.0	11.2	1.6	4	15.0 1/4"
DN20	3/4"	189.0	78.0	98.0	70.0	43.0	11.2	1.6	4	15.0 1/4"
DN25	1"	189.0	92.0	108.0	79.5	51.0	11.2	1.6	4	15.0 1/4"
DN40	1-1/2"	181.0	109.0	127.0	98.5	73.0	14.3	1.6	4	15.0 1/4"
DN50	2"	218.0	146.0	152.0	120.5	92.0	15.9	1.6	4	19.0 1/2"
DN65	2-1/2"	261.0	180.0	178.0	139.5	105.0	17.5	1.6	4	19.0 3/4"
DN80	3"	295.0	200.0	190.0	152.5	127.0	19.1	1.6	4	19.0 1"
DN100	4"	361.0	240.0	229.0	190.5	157.0	23.9	1.6	8	19.0 1-1/2"
DN125	5"	470.0	300.0	254.0	216.0	186.0	24.0	1.6	8	22.0 2"
DN150	6"	469.0	340.0	279.0	241.5	216.0	25.4	1.6	8	22.0 2"
DN200	8"	630.0	460.0	343.0	298.5	270.0	28.6	1.6	8	22.0 2"
DN250	10"	663.0	495.0	406.0	362.0	324.0	30.2	1.6	12	25.0 2"
DN300	12"	772.0	575.0	483.0	432.0	381.0	31.8	1.6	12	25.0 2"
DN350	14"	950.0	736.0	535.0	476.0	413.0	35.0	1.6	12	29.0 2"