

Fig NO. VF-51

1" ~ 6" DN25 ~ DN 150



Feature :

- Investment Casting Component
- ISO 5211 mounting Flange
- Blow-out-proof stem, Anti-Static Design
- For Flow & Steam control
- Carbon steel or Super Alloy upon request

Standard Compliance:

- Body wall thickness : B16.34
- Face to Face : ANSI B16.10 Class 150
- Flange Dimension : ANSI B16.5 Class 150
- Finish : 125- 250 AARH
- Body Material : ASME A351
- Pressure testing : EN12266

Standard Compliance:

- End connection : Flange RF
- Working pressure : 275 psi (CWP)
- Temperature : -20 ~ 220 °C

MATERIALS LIST

NO.	PART NAME	MATERIAL
1	BODY	ASTM A351 Gr.CF8M
4	BALL	ASTM A351 Gr.CF8M
5	STEM	SS316
9	INSERT	ASTM A351 Gr.CF8M
11	BODY SEAL	PTFE.
12	SEAT	50%SS+50%PTFE.
13	THRUST WASHER	PTFE.
14	STEM PACKING	PTFE.
15	GLAND	SS304
17	GLAND PACKING	SS304
19	HANDLE	FCD45
28	STOP PLATE	SS304
41	SNAP RING	SS304
42	GLAND BOLT	SS304
56	BEARING	PTFE.

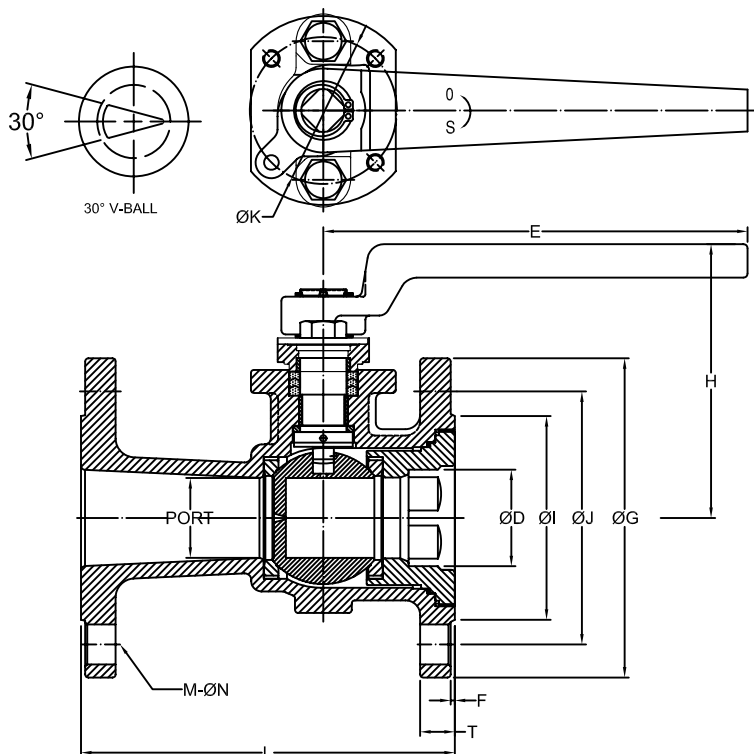
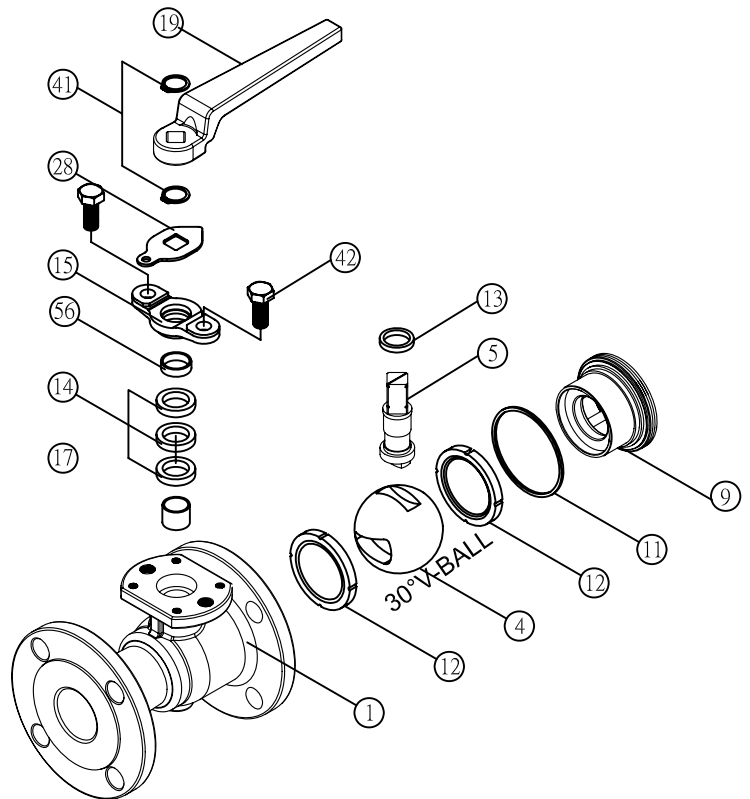

DIMENSIONS

SIZE	PORT	L	E	H	ØG	ØJ	ØI	T	F	M	ØN	ØK	ØD	
DN25	1"	20.0	127.0	130.8	80.2	108.0	79.5	51.0	12.0	2.0	4	16.0	42.0	25.0
DN40	1-1/2"	32.5	165.0	163.0	99.0	127.0	98.5	73.0	14.8	2.0	4	16.0	50.0	38.0
DN50	2"	38.0	178.0	202.0	130.4	152.0	120.5	97.0	16.5	2.0	4	19.0	70.0	46.0
DN65	2-1/2"	50.0	190.0	202.0	137.9	178.0	139.5	105.0	18.0	2.0	4	19.0	70.0	65.0
DN80	3"	58.0	203.0	323.5	159.3	190.0	152.5	127.0	19.5	2.0	4	19.0	102.0	78.0
DN100	4"	80.0	229.0	323.5	182.3	229.0	190.5	163.0	24.3	2.0	8	19.0	102.0	95.0
DN150	6"	115.0	267.0	752.5	241.6	279.0	241.5	216.0	25.4	2.0	8	22.0	125.0	150.0