



**V-255FSA**

**Fire Safe Ball Valve**  
 API 607 6<sup>th</sup> Edition / ISO 10497 Certified  
 DN15 ~ DN65 With 8 Bolts Design  
 PN140/100 / Reduced Bore



0038

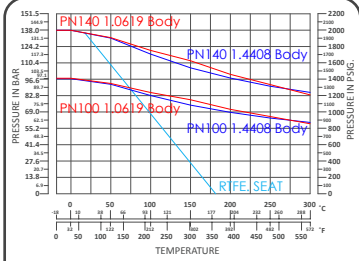

PN140/100 P-T Chart

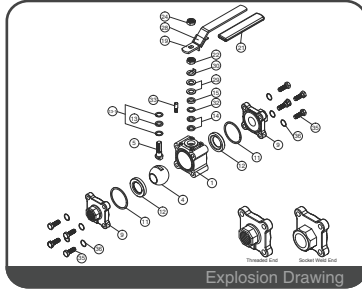

Explosion Drawing

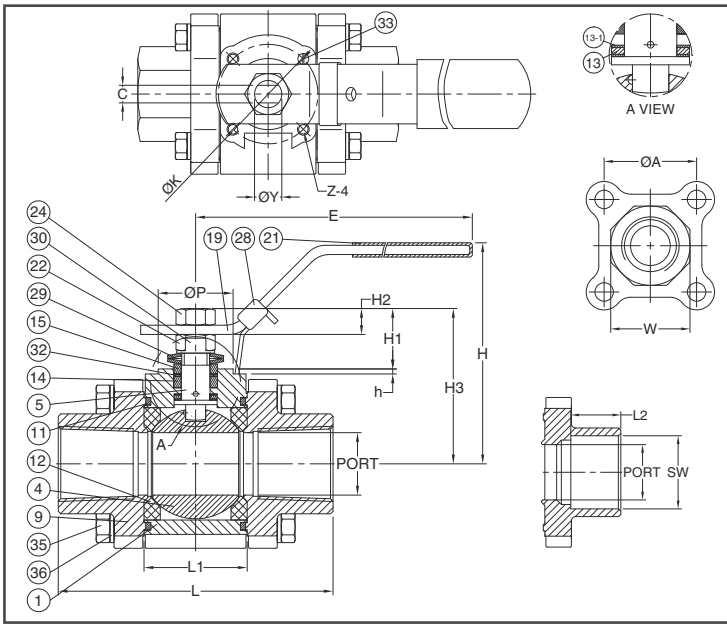

**FEATURES**

- Investment Cast Body Construction
- 3 Pieces Body Design with 8 Bolts
- ISO 5211 Mounting Flange
- Blow-Out-Proof Stem Design & Anti-Static Device
- ABS Type Approval for Marine, Offshore Platform, and Industrial Applications - Water, Oil, and Air
- Available for Pneumatic or Electric Actuator
- NACE MR0175 is available upon request
- Super Alloy materials for highly corrosive medium are available upon request

**AUTOMATION AVAILABLE**

**SPECIFICATIONS**

- Size Range DN15 ~ DN65 ( 1/2" ~ 2-1/2" )
- End Connection Threaded / Socket Weld Ends
- Working Pressure PN140 for DN15 ~ DN32  
PN100 for DN40 ~ DN65
- Steam Pressure 150 psig. Saturated Steam for RTFE.
- Temperature Range -4 to 356 °F ( -20 to 180 °C ) for RTFE.

**STANDARDS**

- Design EN 12516-1/2/3 / API 608 / ANSI B16.34 Class 600
- Mounting Flange ISO 5211
- Threaded End NPT/ BS 21 ( BSP ) / BSPT / ISO 228-1 / DIN 2999 / ISO 7-1Rp
- Socket Weld End ASME/ANSI B16.11
- Face to Face Manufacturer Standards
- Material EN 1503-1
- Pressure Testing EN 12266

**CERTIFICATE**

- Fire Safe API 607 6<sup>th</sup> Edition / ISO 10497 Certified
- Type Approval ABS Type Approval
- CE Approval PED 97/23/EC Module H
- Quality Assurance ISO 9001
- Material Certificate EN 10204-3.1 MTR

**MATERIAL LIST**

NO.	PART NAME	MATERIAL (more options available)
1	BODY	EN1503-1 1.4408 EN1503-1 1.0619
4	BALL	ASTM A351 Gr.CF8M
5	STEM	ASTM A276 Gr.316
9	END CAP	EN1503-1 1.4408 EN1503-1 1.0619
11	BODY SEAL	GRAPHITE
12	SEAT	PTFE. + 25%CARBON
13	THRUST WASHER	GRAPHITE
13-1	THRUST WASHER	RTFE.
14	STEM PACKING	GRAPHITE
15	GLAND BUSH	SS304
19	HANDLE	SS304
21	HANDLE COVER	PLASTIC
22	STEM NUT	SS304
24	HANDLE NUT	SS304
28	LOCKING DEVICE	SS304
29	BELLEVILLE WASHER	SS301
30	TAB WASHER	SS304
32	PACKING FOLLOWER	RTFE.
33	STOP PIN	SS304
35	BODY BOLT	SS304
36	BOLT WASHER	SS304

**DIMENSION**

SIZE	PORT	L	L1	E	H	H1	H2	H3	h	C	ØY	W		ØK	ØP	Z	ØA	L2	SW	
												TH	SW							
DN15	1/2"	10.0	64.8	20.5	132.8	63.7	7.5	6.6	37.1	0.5	6.5	9.5	30.0	30.0	36/F03	25.1	M5	32.0	10.0	21.9
DN20	3/4"	15.0	72.5	24.5	132.8	65.1	17.1	11.1	46.1	2.0	6.5	9.5	36.0	36.0	36/F03	25.0	M5	35.0	13.0	27.3
DN25	1"	20.0	84.2	31.4	132.8	73.2	18.1	9.1	50.9	2.0	6.5	9.5	44.5	44.5	36/F03	25.0	M5	41.3	13.0	33.9
DN32	1-1/4"	25.0	105.3	41.3	171.8	83.1	25.4	13.1	61.4	2.0	8.0	11.1	54.0	54.0	42/F04	30.0	M5	48.0	13.0	42.8
DN40	1-1/2"	32.0	111.0	48.4	171.8	87.6	26.2	12.6	66.8	2.0	8.0	11.1	60.0	60.0	42/F04	30.0	M5	56.2	13.0	48.9
DN50	2"	38.0	127.3	56.3	204.2	98.4	32.4	14.9	80.0	2.2	9.7	14.2	68.0	73.2	50/F05	35.0	M6	63.6	16.0	61.3
DN65	2-1/2"	50.0	153.4	72.0	211.0	130.0	28.5	15.5	99.4	1.5	12.0	19.05	86.0	86.0	70/F07	55.0	M8	79.2	16.0	74.0

**DIMENSION**

SIZE	PORT	L	L1	E	H	H1	H2	H3	h	C	ØY	W		ØK	ØP	Z	ØA	L2	SW	
												TH	SW							
DN15	1/2"	0.39	2.55	0.81	5.23	2.51	0.30	0.26	1.46	0.02	0.26	0.37	1.18	1.18	1.42/F03	0.99	M5	1.26	0.39	0.86
DN20	3/4"	0.59	2.85	0.96	5.23	2.56	0.67	0.44	1.81	0.08	0.26	0.37	1.42	1.42	1.42/F03	0.98	M5	1.38	0.51	1.07
DN25	1"	0.79	3.31	1.24	5.23	2.88	0.71	0.36	2.00	0.08	0.26	0.37	1.75	1.75	1.42/F03	0.98	M5	1.63	0.51	1.33
DN32	1-1/4"	0.98	4.15	1.63	6.76	3.27	1.00	0.52	2.42	0.08	0.31	0.44	2.13	2.13	1.65/F04	1.18	M5	1.89	0.51	1.69
DN40	1-1/2"	1.26	4.37	1.91	6.76	3.45	1.03	0.50	2.63	0.08	0.31	0.44	2.36	2.36	1.65/F04	1.18	M5	2.21	0.51	1.93
DN50	2"	1.50	5.01	2.22	8.04	3.87	1.28	0.59	3.15	0.09	0.38	0.56	2.68	2.88	1.97/F05	1.38	M6	2.50	0.63	2.41
DN65	2-1/2"	1.97	6.04	2.83	8.31	5.12	1.12	0.61	3.91	0.06	0.47	0.75	3.39	3.39	2.76/F07	2.17	M8	3.12	0.63	2.91