

Fig No. K-306L/T Standard Bore
1/4" ~ 2" DN 8- DN 50



Features :

- Investment Casting
- Blow out proof stem
- 360 degree rotation design
- For Chemical, Industrial Application
- Carbon Steel or Super Alloy upon request

Standard Compliance :

- Body wall thickness : EN 12516-1/3
- Threaded end : BS 21 (BSP)
- BSPT
- ISO 228-1G
- DIN 2999
- ISO 7-1Rp
- Face to Face : MD's standard
- Body material : EN1503-1
- Pressure testing : EN 12266

Specification :

- End connection : Threaded end
- Working pressure : 61.2 bar (RT)
- Temperature : -20 to 180⁰C

MATERIALS LIST

NO.	PART NAME	MATERIAL
1	BODY	1.4408/EN1503-1
4	BALL	ASTM A351 Gr.CF8M
5	STEM	SS316
9	END CAP	1.4408/EN1503-1
11	BODY SEAL	PTFE.
12	SEAT	PTFE.
13	THRUST WASHER	PTFE.
14	STEM PACKING	PTFE.
16	GLAND NUT	SS304
19	HANDLE	SS304
20	SET SCREW	SS304
21	HANDLE COVER	PLASTIC
23	SPRING WAHSER	SS304
23-1	SPRING WAHSER	SS304
24	HANDLE NUT	SS304
28	LOCKING DEVICE	SS304
33	STOP PIN	SS304

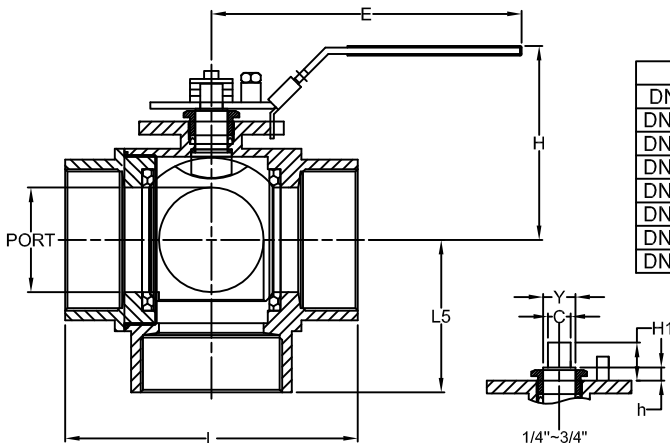
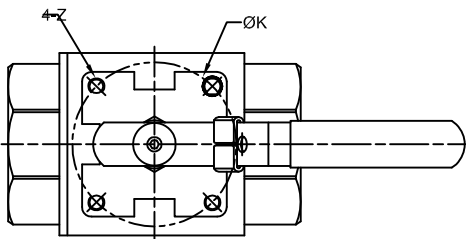
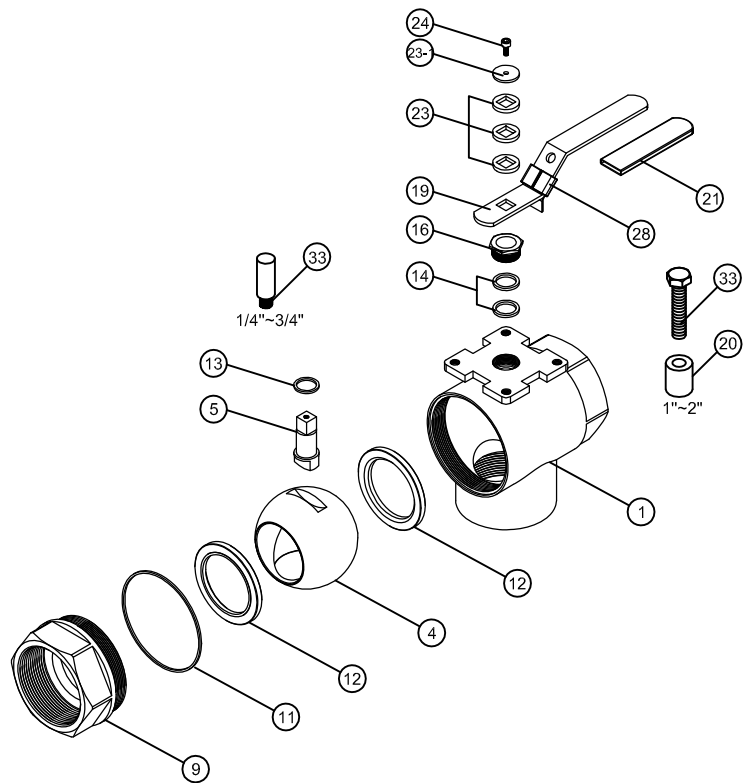

DIMENSIONS

SIZE	PORT	L	L5	E	H	H1	h	C	ØY	ØK	Z	unit:mm
DN8	1/4"	11.0	57.2	29.0	133.4	62.7	10.9	5.9	9.0	12.0	36.0	M5*0.8
DN10	3/8"	11.0	57.2	29.0	133.4	62.7	10.9	5.9	9.0	12.0	36.0	M5*0.8
DN15	1/2"	12.5	66.0	34.5	133.4	64.7	10.9	5.9	9.0	12.0	36.0	M5*0.8
DN20	3/4"	16.0	85.8	39.7	133.4	78.7	11.4	6.4	9.0	12.0	36.0	M5*0.8
DN25	1"	20.0	88.5	46.0	133.4	71.2	11.4	6.4	9.0	12.0	42.0	M5*0.8
DN32	1-1/4"	25.4	103.4	51.7	178.5	90.2	23.7	8.2	11.0	15.0	50.0	M6*1.0
DN40	1-1/2"	31.8	111.1	61.0	178.5	93.7	23.7	8.2	11.0	15.0	50.0	M6*1.0
DN50	2"	38.1	136.4	71.4	178.5	98.2	23.7	8.2	11.0	15.0	50.0	M6*1.0