

Fig no. HPV-41T Full Bore
1/4" ~ 2" DN 8- DN 50



Features :

- Bar material ball valve, ISO 5211 Mounting Flange
- Blow out proof stem, Anti-static design
- 360 degree rotation design
- For Chemical, Industrial Application, In-line Maintenance
- Super Alloy upon request

Standard Compliance :

- Body wall thickness : EN 12516-1/2
- Threaded end : BS 21 (BSP)
- BSPT
- ISO 228-1G
- DIN 2999
- ISO 7-1Rp

- Face to Face : MD's standard
- Body material : DIN
- Pressure testing : EN 12266

Specification :

- End connection : Threaded end
- Working Pressure : 420 bar (CWP)
- Temperature : -20 to 80°C for Delrin
- 20 to 250°C for Peek

MATERIALS LIST

NO.	PART NAME	MATERIAL
1	BODY	1.1141
4	BALL	ASTM A351 Gr.CF8M
5	STEM	17-4PH
9	END CAP	1.1141
11	BODY SEAL	DELTRIN/GRAPHITE
11-1	BODY SEAL	PTFE
12	SEAT	DELTRIN/PEEK
13	THRUST WASHER	DELTRIN/PEEK
14	STEM PACKING	PTFE.+25%C.F.
15	GLAND BUSH	SS304
19	HANDLE	SS304
20	SET SCREW	SS304
21	HANDLE COVER	PLASTIC
22	STEM NUT	SS304
24	HANDLE NUT	ASTM A2 70
28	STOP PLATE	SS304
29	BELLEVILLE WASHER	SS304-CSP
30	TAB WASHER	SS304
31	O-RING	VITON
32	PACKING FOLLOWER	TFM1600
33	STOP PIN	SS304
35	BODY BOLT	SCM440
36	BOLT WASHER	S45C
37	NUT	S45C
50	STEM ADAPTER	SS304

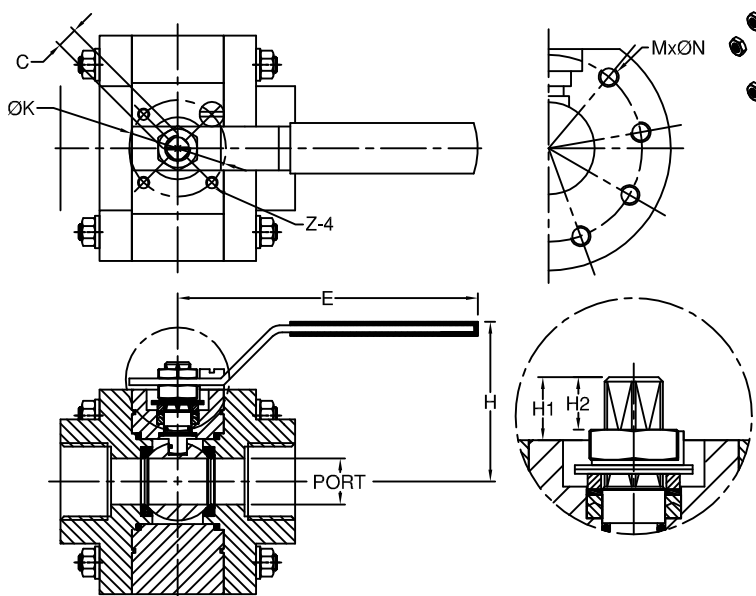
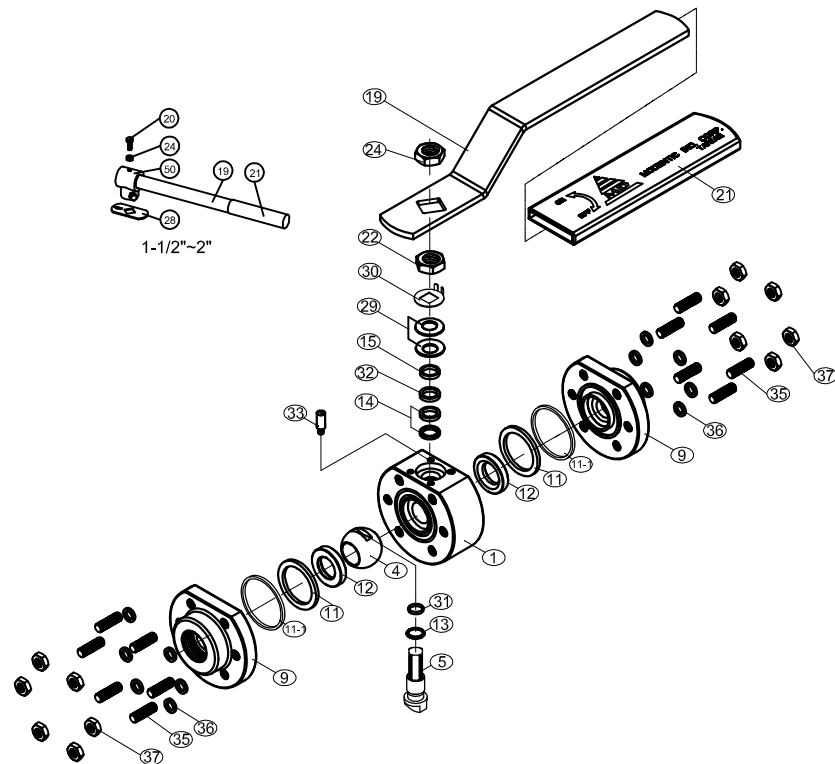

DIMENSIONS

SIZE	PORT	L	E	H	H1	H2	C	M	ØK	Z		
DN8	1/4"	9.5	85.0	151.0	61.0	10.1	7.0	9.0	6	5/16"-18UNC	36.0	M5
DN10	3/8"	11.6	85.0	151.0	61.0	10.1	7.0	9.0	6	5/16"-18UNC	36.0	M5
DN15	1/2"	16.0	89.0	151.0	67.0	14.85	10.3	9.0	8	5/16"-18UNC	42.0	M5
DN20	3/4"	20.0	102.0	183.0	81.0	12.0	10.0	9.0	8	5/16"-18UNC	42.0	M5
DN25	1"	25.0	111.0	183.0	97.0	22.3	11.5	11.0	8	5/16"-18UNC	42.0	M5
DN32	1-1/4"	32.0	119.0	285.0	113.0	33.2	17.5	14.0	8	3/8"-16UNC	50.0	M6
DN40	1-1/2"	38.0	126.0	285.0	117.0	28.0	17.5	14.0	8	1/2"-13UNC	50.0	M6
DN50	2"	50.0	148.0	285.0	125.0	28.0	17.5	14.0	8	9/16"-12UNC	50.0	M6

unit:mm