

UMS Direct Mount Series

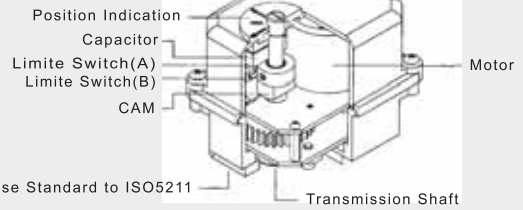
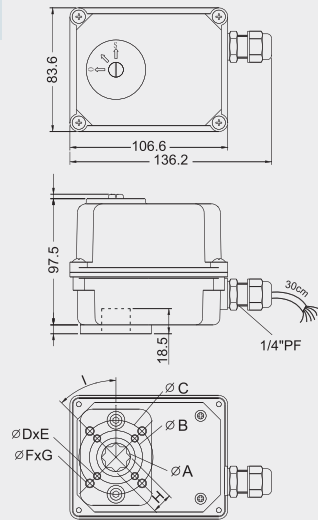

Base Standard to ISO5211

Power	Specification			Speed(sec)		Output Torque Kgf-cm		
	24VAC	110VAC	220VAC	AC	DC	24VAC	110VAC	220VAC
3~4W	170 mA	33 mA	30 mA	23	N/A	150	150	150

* Option : (1) H=9°, A=12 (2) H=11°, A=15

* F04/F07 D=M5, F=M8 Optional

Dimension (mm) Model	Dimension (mm)											ISO 5211
	A	B	C	D	E	F	G	H Max	I	J	K	
UMS	19	36	50	M5	4	M6	4	14	45°	F03 / F05		

UM-1 Direct Mount Series

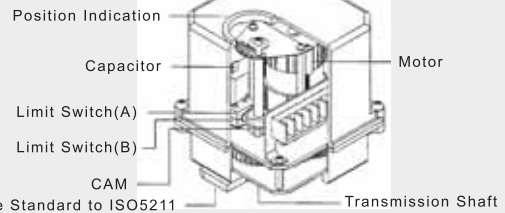
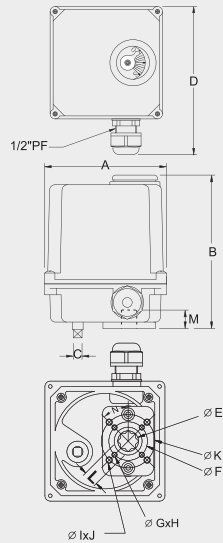

Base Standard to ISO5211

Power	Specification			Speed(sec)		Output Torque Kgf-cm		
	110VAC	220VAC	24VDC	AC	DC	110VAC	220VAC	24VDC
10W	0.4A	0.25A	0.5A	10	15	350	362	438
15W	0.8A	0.5A	N/A	10	N/A	410	432	N/A

Dimension (mm) Model	Dimension (mm)													ISO 5211	
	A	B	C	D	E	F	G	H	I	J	K	L Max	M		N
UM-1	112	144	8	148	19	36	M5	4	M6	4	50	14	18.5	45°	F03 / F05

UM-2 Direct Mount Series

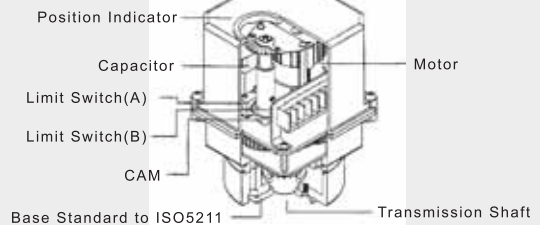
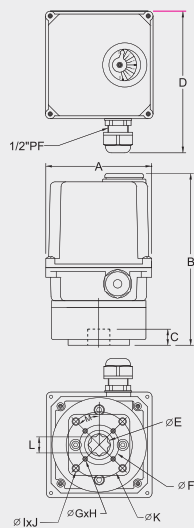

Base Standard to ISO5211

Power	Specification			Speed(sec)		Output Torque Kgf-cm		
	110VAC	220VAC	24VDC	AC	DC	110VAC	220VAC	24VDC
10W	0.4A	0.25A	0.5A	20	30	480	502	622
15W	0.8A	0.5A	N/A	20	N/A	655	677	N/A

Dimension (mm) Model	Dimension (mm)													ISO 5211
	A	B	C	D	E	F	G	H	I	J	K	L Max	M	
UM-2	112	185	19.5	148	23.5	42	M5	4	M8	4	70	17	45°	F04 / F07

UM-3 Direct Mount Series

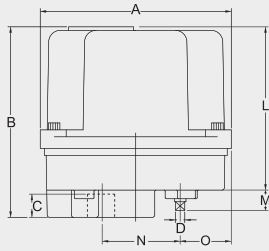

*The UM-3/24VDC is over standard height 26mm.

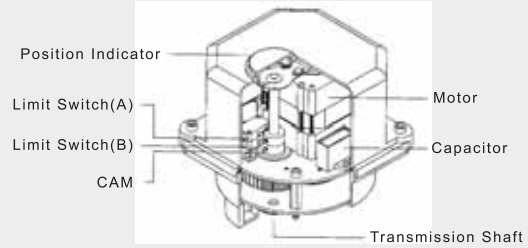
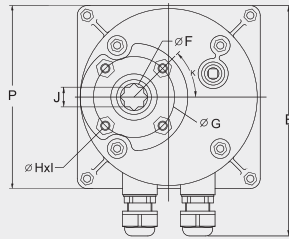

Power	Specification				Speed(sec)		Output Torque Kgf-cm		
	110VAC	220VAC	24VDC		AC	DC	110VAC	220VAC	24VDC
25W	0.76A	0.42A	N/A		1	N/A	294	350	N/A
					8		1486	1562	
30W	N/A		0.5A		N/A	1	N/A		506
						8			1660

Dimension (mm) Model	A	B	C	D	E	F	G	H	I	J	K	L	M	N	O	P	ISO 5211
	UM-3	165	165	20	8	200	23.5	70	M8	M6	17	45°	141	17.3	68.39	44.2	16

UM-3-1 Direct Mount Series

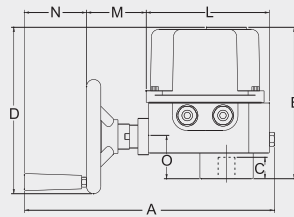

*The UM-3-1/24VDC is over standard height 26mm.

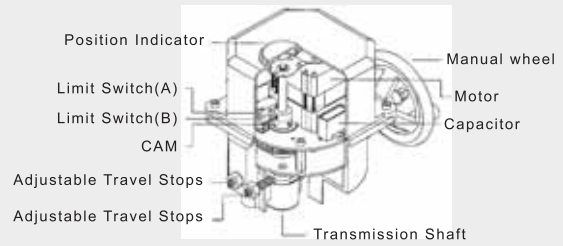
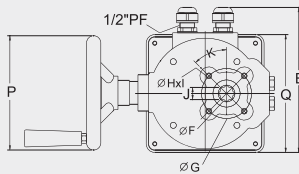

Power	Specification				Speed(sec)		Output Torque Kgf-cm		
	110VAC	220VAC	24VDC		AC	DC	110VAC	220VAC	24VDC
25W	0.76A	0.42A	N/A		1	N/A	294	350	N/A
					8		1486	1562	
30W	N/A		0.5A		N/A	1	N/A		506
						8			1660

Dimension (mm) Model	A	B	C	D	E	F	G	H	I	J	K	L	M	N	O	P	Q	ISO 5211
	UM-3-1	350	215	30	235	203	23.5	70	M5	4	17	45°	173	84	87	59	160	165

UM-3 Direct Mount Series

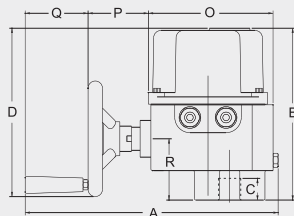

*The UM-4/24VDC is over standard height 26mm.

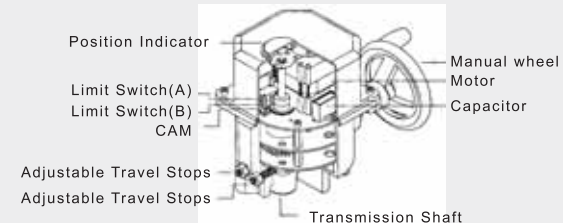
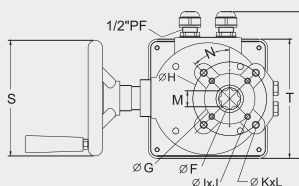

Power	Specification				Speed(sec)		Output Torque Kgf-cm		
	110VAC	220VAC	24VDC		AC	DC	110VAC	220VAC	24VDC
25W	0.76A	0.42A	N/A		20	N/A	2500	2500	N/A
					30		3118	3320	
30W	N/A		0.5A		N/A	20	N/A		2630
						30			3400

Dimension (mm) Model	A	B	C	D	E	F	G	H	I	J	K	L	M	N	O	P	Q	R	S	T	ISO 5211
	UM-4	350	240	30	235	203	30.6	70	102	M8	4	M10	4	22	45°	173	84	87	85	160	165

UM-5 Direct Mount Series

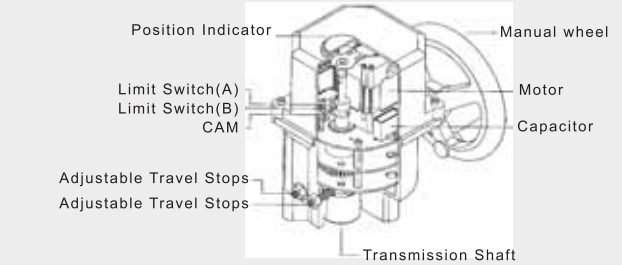
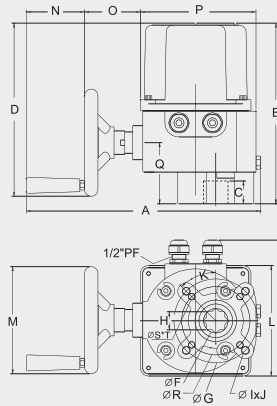

Specification	Speed(sec)		Output Troque Kgf-cm				
	110VAC	220VAC	AC	DC	110VAC	220VAC	24VDC
Power	110VAC	220VAC	30	N/A	4266	4873	N/A
40W	0.95A	0.58A					

Dimension (mm) Model	A	B	C	D	E	F	G	H	I	J	K	L	M	N	O	P	Q	R	S	T	ISO 5211
	UM-5	350	272	34	260	203	36.6	125	27	M12	4	45°	165	200	87	84	173	92	102	M10	4

UM-6 Direct Mount Series

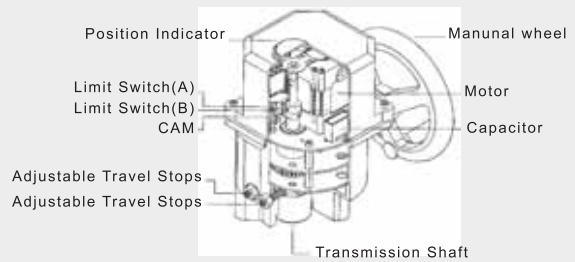
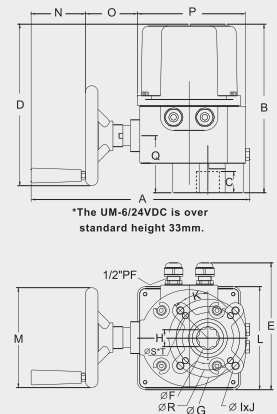

Specification	Speed(sec)			Output Troque Kgf-cm				
	110VAC	220VAC	24VAC	AC	DC	110VAC	220VAC	24VDC
Power	110VAC	220VAC	24VAC	30	N/A	5689	6081	N/A
60W	1.2A	0.66A	N/A					
65W	N/A	N/A	1.5A	N/A	30	N/A		6232

Dimension (mm) Model	A	B	C	D	E	F	G	H	I	J	K	L	M	N	O	P	Q	R	S	T	ISO 5211
	UM-6	350	272	34	260	203	36.6	125	27	M12	4	45°	165	200	87	84	173	92	102	M10	4

UM-8 Series

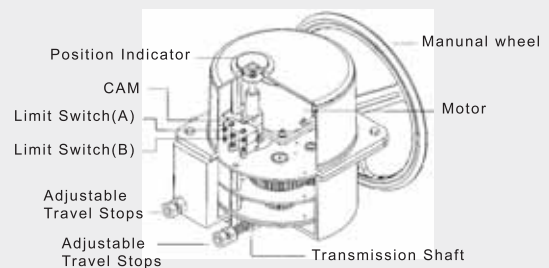
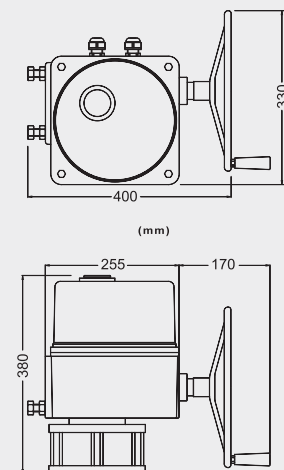

Specification	Speed(sec)		Output Troque Kgf-cm				
	110VAC	220VAC	AC	DC	110VAC	220VAC	24VDC
Power	110VAC	220VAC	37	N/A	11038	9296	N/A
100W	0.92A	0.34A					

UM-10 Series

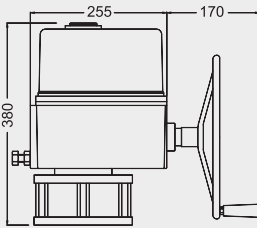
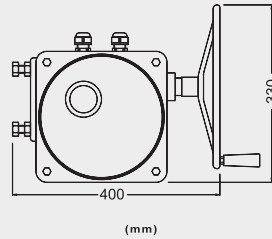

Mounting pattern is depending on valve

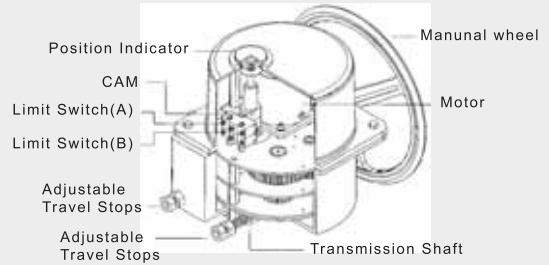

Power	Specification		Speed(sec)		Output Troque Kgf-cm		
	110VAC	220VAC	AC	DC	110VAC	220VAC	24VDC
100W	0.92A	0.34A	52	N/A	12060	13500	N/A

UM-11 Series

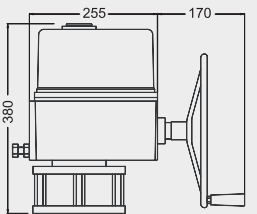
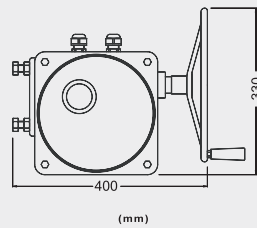

Mounting pattern is depending on valve

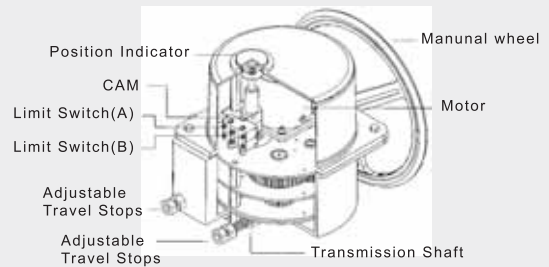

Power	Specification		Speed(sec)		Output Troque Kgf-cm		
	110VAC	220VAC	AC	DC	110VAC	220VAC	24VDC
100W	0.92A	0.34A	65	N/A	15000	14500	N/A

UM-12 Series

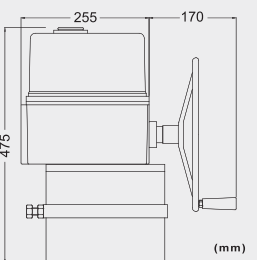
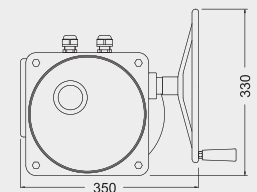

Mounting pattern is depending on valve

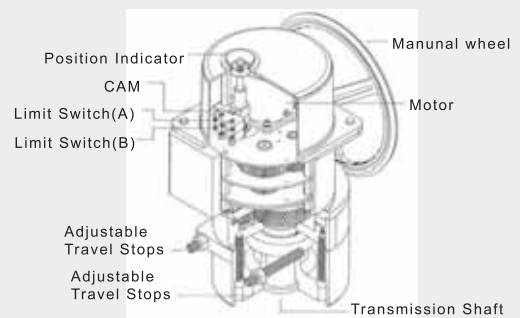

Power	Specification		Speed(sec)		Output Troque Kgf-cm		
	110VAC	220VAC	AC	DC	110VAC	220VAC	24VDC
100W	0.92A	0.34A	143	N/A	35000	35000	N/A

24VAC Specification

Model	Power	Speed 90° sec(60Hz)	Torque (±5%) kgf-cm 24VAC	24VAC	Weight (kg)	ISO 5211 Mounting Pattern
UMS	3-4W	23	150	170mA	1	O

110VAC/220VAC Specification

Model	Power	Speed 90° sec(60Hz)	Torque (±5%) kgf-cm 110VAC	Torque (±5%) kgf-cm 220VAC	110VAC	220VAC	Weight (kg)	ISO 5211 Mounting Pattern
UMS	3-4W	23	150	150	33mA	30mA	1	O
UM-1	10W	5	181	214	0.4A	0.25A	1.5	O
UM-1	10W	10	350	362	0.4A	0.25A	1.5	O
UM-1	15W	10	410	432	0.8A	0.5A	1.5	O
UM-2	10W	20	480	502	0.4A	0.25A	2.3	O
UM-2	15W	20	655	677	0.8A	0.5A	2.3	O
UM-3	25W	1	294	350	0.76A	0.42A	6	O
UM-3	25W	8	1486	1562	0.76A	0.42A	6	O
UM-3	40W	1	369	405	0.95A	0.58A	6	O
UM-3	60W	1	445	460	1.2A	0.66A	6	O
UM-3-1	25W	1	294	350	0.76A	0.42A	7.5	O
UM-3-1	40W	1	369	405	0.95A	0.58A	7.5	O
UM-3-1	60W	1	445	460	1.2A	0.66A	7.5	O
UM-4	25W	20	2500	2500	0.76A	0.42A	8.3	O
UM-4	25W	30	3188	3320	0.76A	0.42A	8.3	O
UM-5	40W	30	4266	4873	0.95A	0.58A	10.8	O
UM-6	60W	30	5689	6081	1.2A	0.66A	11	O
UM-8	100W	37	11038	9296	0.92A	0.34A	32	
UM-10	100W	52	12060	13500	0.92A	0.34A	34	
UM-11	100W	65	15000	14500	0.92A	0.34A	34	
UM-12	100W	143	35000	35000	0.92A	0.34A	60	

24VDC Specification

Model	Power	Speed 90° sec(60Hz)	Torque (±5%) kgf-cm 24VAC	24VAC	Weight (kg)	ISO 5211 Mounting Pattern
UM-1	10W	15	438	0.5A	1.5	O
UM-2	10W	30	622	0.5A	2.3	O
UM-3	30W	1	506	0.5A	6	O
UM-3	30W	8	1660	0.5A	6	O
UM-3-1	30W	1	506	0.5A	7.5	O
UM-3-1	30W	8	1660	0.5A	7.5	O
UM-4	30W	20	2630	0.5A	8.3	O
UM-4	30W	30	3405	0.5A	8.3	O
UM-6	65W	30	6232	1.5A	11	O