

Fig No:EL-318

1/2" ~ 2" (DN 8~ DN 50)



Valve Specification :

Design specification according to EN 12516-1

L-Port / T-Port , Four Seat design

Material : Stainless Steel, Carbon Steel or Special Alloy upon request

Blow-out-proof stem design , Anti-static design

Actuator mounting shall be in accordance with ISO 5211

Working Pressure (CWP) : 1000 Psi

Temperature Range : -4 to 356 °F (-20 to 180 °C)

Pressure Test According to API 598

Shell test by water : 1500 Psi

Closure seat by Air : 80 ~ 100 Psi

PORT TYPE	1	2	3	4
L	1 3	2 3	1 3	2 3
T	1 3	1 3	2 3	2 3

MATERIALS LIST

NO	PART NAME	MATERIAL	Q'TY
1	BODY	ASTM A351 GR. CF8M	1
2	BALL	ASTM A351 GR. CF8M	1
3	END CAP	ASTM A351 GR. CF8M	3
4	BODY SEAL	PTFE.	3
5	STEM	SS316	1
6	FOLLOWER	SS304	1
7	STEM PACKING	PTFE.	1 SET
9	SEAT	PTFE.	4
10	THRUST WASHER	PTFE.	1
20	BOLT	SS304	4
21	BEVELILLE WASHER	SS301	1 SET
40	ELECTRIC ACTUATOR	NYLON	1

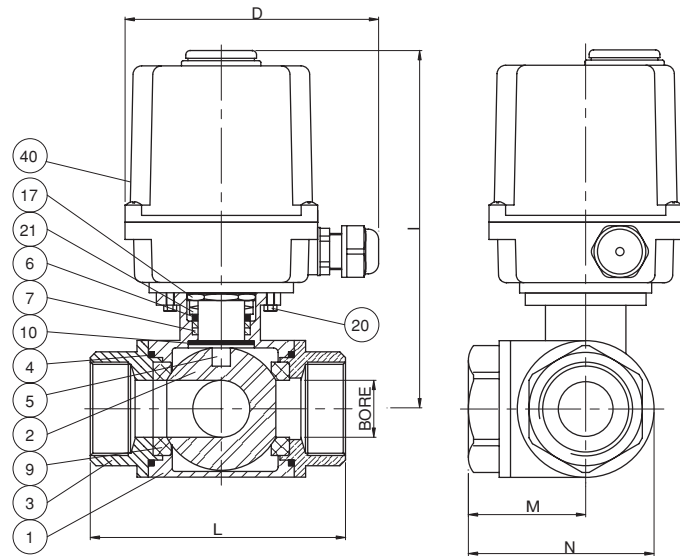

DIMENSIONS

Unit:mm

SIZE	1/2"				3/4"				1"				1-1/4"				1-1/2"				2"				
ELECTRIC FIG.	UMS		UM-1		UM-1				UM-2		UM-1		UM-2				UM-3				UM-2				
VOLTAGE	110 VAC	220 VAC	24 VAC	24 DVC	110 VAC	220 VAC	24 VAC	24 DVC	110 VAC	220 VAC	24 VAC	24 DVC	110 VAC	220 VAC	24 VAC	24 DVC	110 VAC	220 VAC	24 VAC	24 DVC	110 VAC	220 VAC	24 VAC	24 DVC	
BORE	12.7				16.0				20.0				25.0				32.0				38.0				
D	136.2	136.2	136.2	148.0	148.0	148.0	148.0	148.0	148.0	148.0	148.0	148.0	148.0	148.0	148.0	148.0	200.0	200.0	200.0	200.0	200.0	200.0	200.0	200.0	200.0
I	138.2	138.2	138.2	184.7	189.2	189.2	189.2	189.2	241.5	241.5	200.5	200.5	246.9	246.9	246.9	246.9	243.3	243.3	243.3	243.3	252.4	252.4	252.4	252.4	
L	75.7				86.6				102.4				118.2				125.8				149.0				
M	37.3				45.7				52.1				58.7				63.7				75.9				
N	61.0				73.0				83.0				95.0				104.5				126.0				