

Fig no. HPV-40FS **Reduced Bore**
1/4" - 2" DN8 - DN50



Features :

- BS 6755 PART2 API 607 5th Fire safe approved
- Bar material valve body, ISO 5211 Mounting flange
- Blow out proof stem, Anti-static design
- 360 degree rotation design, in-line maintenance
- For Chemical, Industrial application
- Carbon Steel, Super Alloy available upon request

Standard Compliance

- Body wall thickness : EN 12516-1/2
- Butt weld end : B16.25
- Face to face : MD's standard
- Body material : DIN
- Pressure testing : EN12266
- Fire safe testing : API 607 5th, BS6755 PART 2
ISO 10497

Specification :

- End Connection : Butt Weld
- Working pressure : 246 bar (CWP)
- Temperature : -20°C to 80°C for Delrin seat
-20°C to 250°C for Peek seat

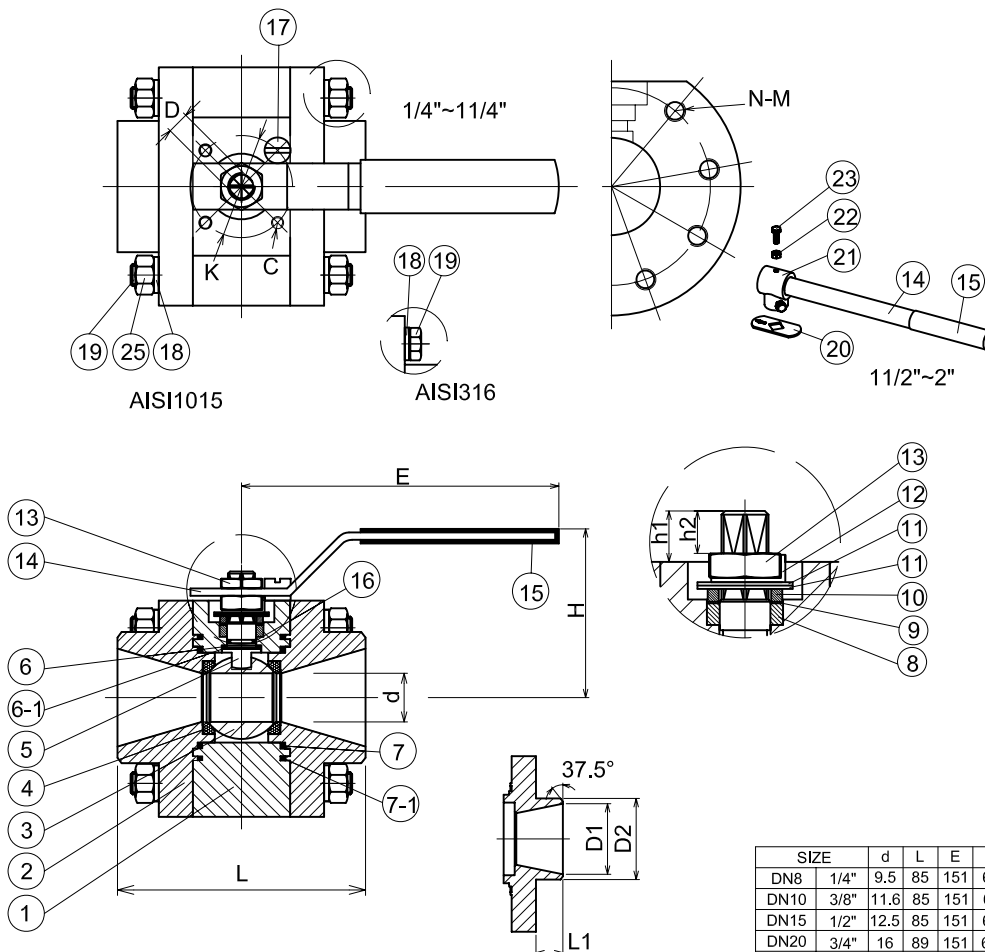

MATERIALS LIST

NO	PART NAME	MATERIAL
1	BODY	1.4401 (AISI 316)
2	CAP	1.4401 (AISI 316)
3	BALL	ASTM A351 Gr.CF8M
4	BALL SEATS	Delrin/ Peek
5	STEM	17-4PH
6	THRUST WASHER	Graphite
6-1	THRUST WASHER	PTFE
7	END SEALS	Graphite
7-1	END SEALS	PTFE
8	STEM PACKING	Graphite
9	THRUST WASHER	TFM1600
10	GLAND BUSH	S.S.304
11	BELLEVILLE WASAER	SUS304-CSP
12	STOP	S.S.304
13	HANDLE NUT	S.S.304
14	HANDLE	S.S.304
15	HANDLE SLEEVE	VINYL GRIP
16	O-RING	VITON
17	STOPPER	S.S.304
18	SPRING WASHER	S.S.304
19	BOLT	S.S.304
20	STOP PLATE	S.S.304
21	STEM ADAPTER	CF8
22	NUT	A2-70
23	BOLT	S.S.304
25	NUT	S 45C

DIMENSIONS

SIZE	d	L	E	H	D	K	C	h1	h2	N	M	L1	D2	D1	
DN8	1/4"	9.5	85	151	61	9	36	M5	10.1	7	6	5/16-18UNC	13	13.7	9.2
DN10	3/8"	11.6	85	151	61	9	36	M5	10.1	7	6	5/16-18UNC	13	17.1	12.5
DN15	1/2"	12.5	85	151	61	9	36	M5	10.1	7	6	5/16-18UNC	13	21.3	15.8
DN20	3/4"	16	89	151	67	9	42	M5	14.85	10.3	8	5/16-18UNC	13	26.7	20.9
DN25	1"	20	102	183	81	9	42	M5	12	10	8	5/16-18UNC	17	33.4	26.6
DN30	1 1/4"	25	111	183	97	11	42	M5	22.3	11.5	8	5/16-18UNC	20	42.2	35.1
DN40	1 1/2"	32	119	285	113	14	50	M6	33.2	17.5	8	3/8-16UNC	20	48.3	40.9
DN50	2"	38	126	285	117	14	50	M6	28	17.5	8	1/2-13UNC	20	60.3	52.5