

Fig No. MD-52FS Full Bore
1/2" - 6" DN 15 ~ DN 150



MATERIALS LIST

NO.	PART NAME	MATERIAL
1	BODY	ASTM A351 Gr.CF8M
4	BALL	ASTM A351 Gr.CF8M
5	STEM	SS316
9	END CAP	ASTM A351 Gr.CF8M
11	BODY SEAL	316/GRAPHITE
12	SEAT	RPTFE.
13	THRUST WASHER	GRAPHITE
13-1	THRUST WASHER	PTFE.
14	STEM PACKING	GRAPHITE
15	GLAND	ASTM A351 Gr.CF8
19	HANDLE	FCD45
28	STOP PLATE	SS304
32	PACKING FOLLWER	PTFE.
35	STUD	SS304
37	BOLT NUT	SS304
41	SNAP RING	SS304
42	GLAND BOLT	SS304
56	BEARING	PTFE.

Features :

- API 607 4th Fire Safe Approved
- Investment casting component
- Blow out proof design, Anti-static device
- ISO 5211 Mounting flange
- For General chemical and industrial application
- Carbon Steel or Super Alloy available upon request

Standard Compliance :

- Body wall thickness : B16.34
- Face to face length : ANSI B16.10 Class 300
- Flange dimension : ANSI B 16.5 Class 300
- Finish : 125-250 AARH
- Body Material : ASTM A351
- Pressure testing : EN 12266

Specification :

- End connection : Flanged RF end
- Working pressure : 720 psi (CWP)
- Temperature : -20 ~ 180°C

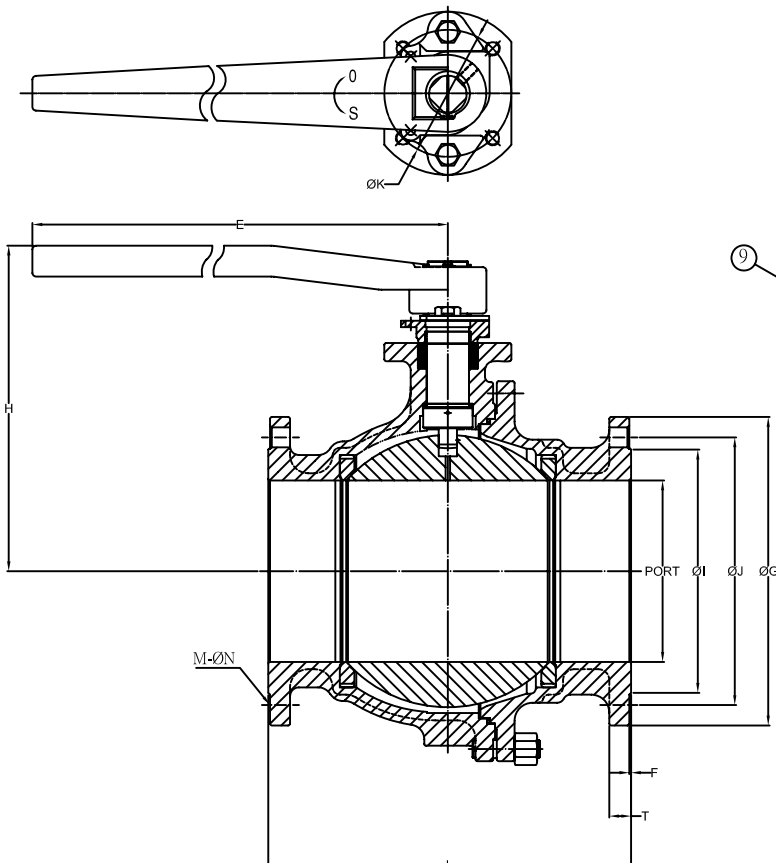
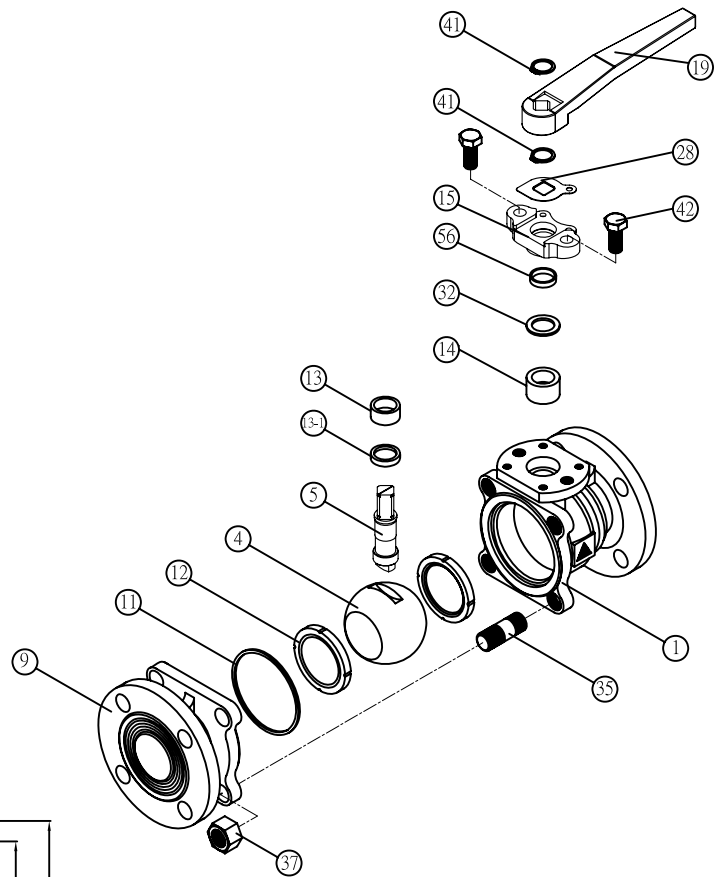

DIMENSIONS

SIZE	PORT	L	E	H	OG	OJ	OI	T	F	M	ON	OK	
DN15	1/2"	15.0	140.0	130.8	77.7	95.0	66.5	35.0	14.3	2.0	4	16.0	42.0
DN20	3/4"	20.0	152.0	130.8	80.2	117.0	82.5	43.0	15.9	2.0	4	19.0	42.0
DN25	1"	25.4	165.0	163.0	92.1	124.0	89.0	51.0	17.5	2.0	4	19.0	50.0
DN40	1-1/2"	38.0	190.0	202.0	130.4	156.0	114.5	73.0	20.7	2.0	4	22.0	70.0
DN50	2"	50.0	216.0	202.0	137.9	165.0	127.0	92.0	22.3	2.0	8	19.0	70.0
DN65	2-1/2"	63.0	241.0	202.0	160.5	190.0	149.0	105.0	25.4	2.0	8	22.0	70.0
DN80	3"	80.0	283.0	323.5	174.7	210.0	168.0	127.0	28.6	2.0	8	22.0	102.0
DN100	4"	98.0	305.0	323.5	197.0	254.0	200.0	157.0	31.8	2.0	8	22.0	102.0
DN150	6"	152.0	403.0	752.5	267.5	318.0	270.0	216.0	36.6	2.0	12	22.0	125.0